

**COLUMN NO/LATH**

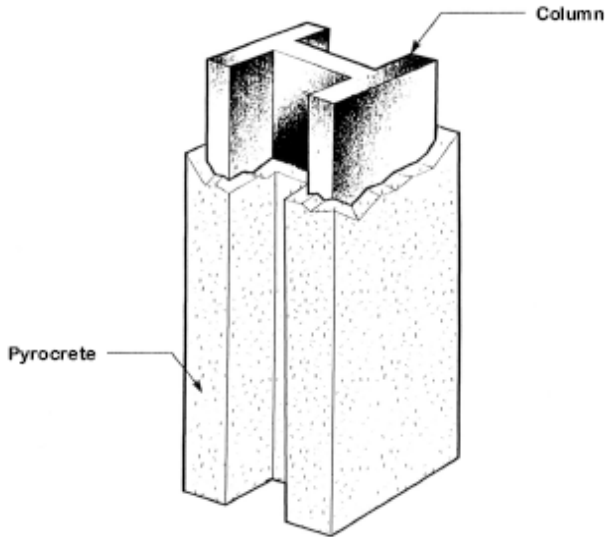

**COLUMN W/LATH**

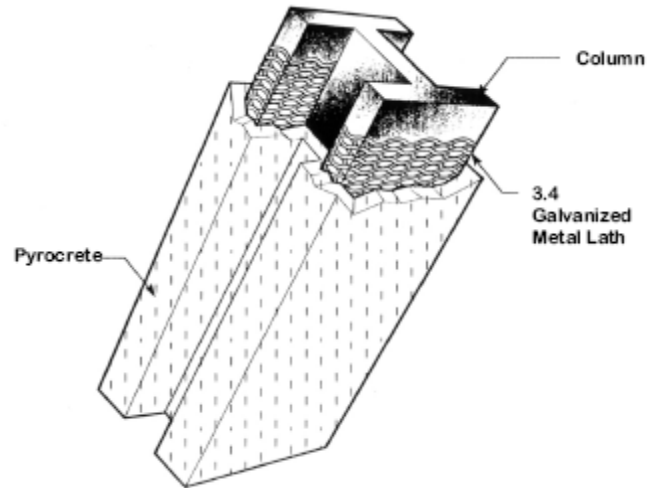

**PLASTIC EDGE CORNER BEAD**

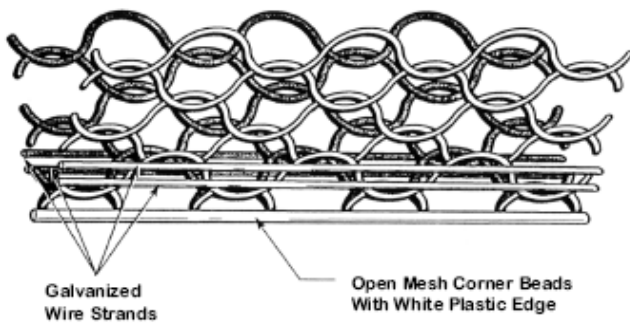

**COLUMN W/CORNER BEAD**

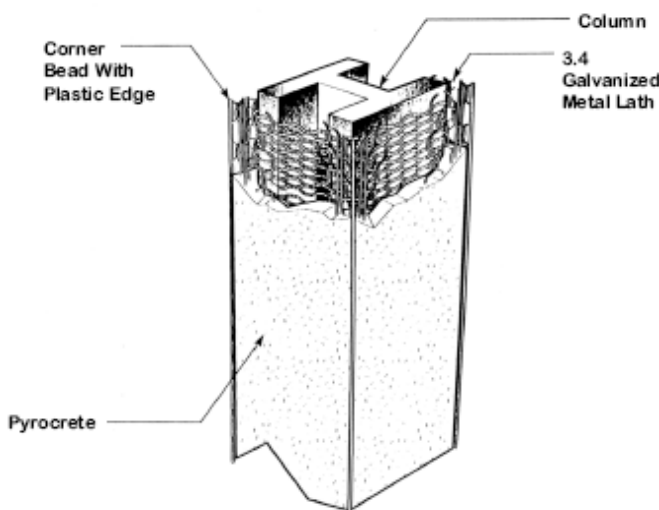

**CONTOUR PIPE RACK WEB > 12"**

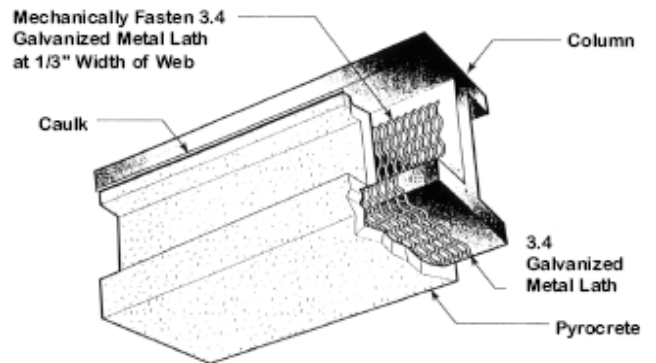

**BOXED PIPERACK**

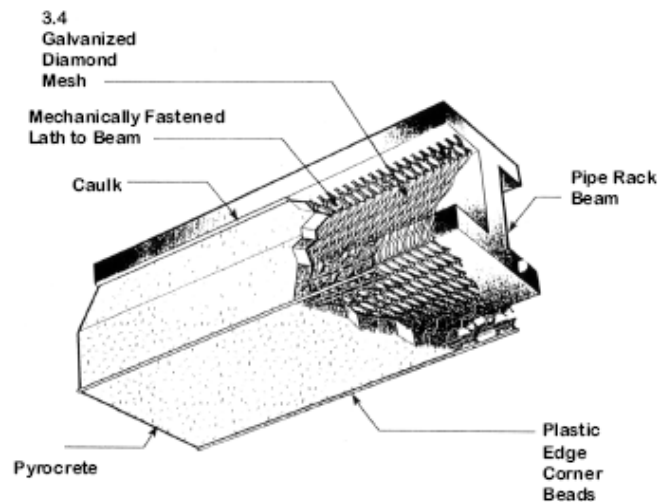

**Notes:** "3.4 Galv Lath" = 1.3 kg / m<sup>2</sup> lath

## COLUMN RAIN CAP

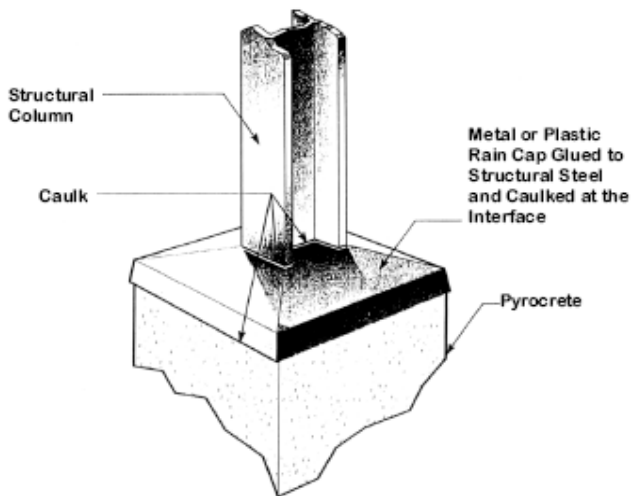

## COLUMN (BOLTED BASE PLATE)

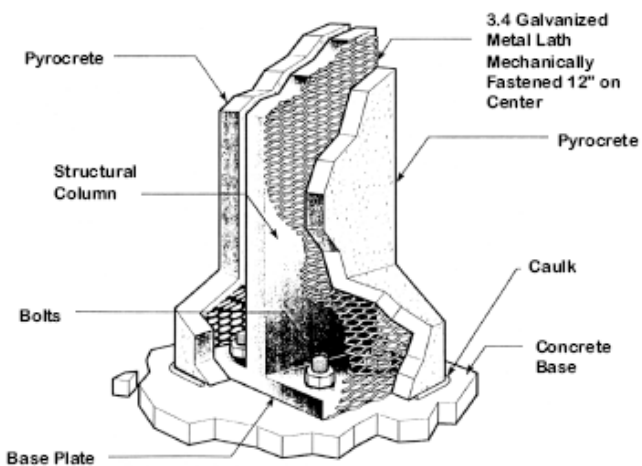

## COLUMN BOLTED CONNECTION

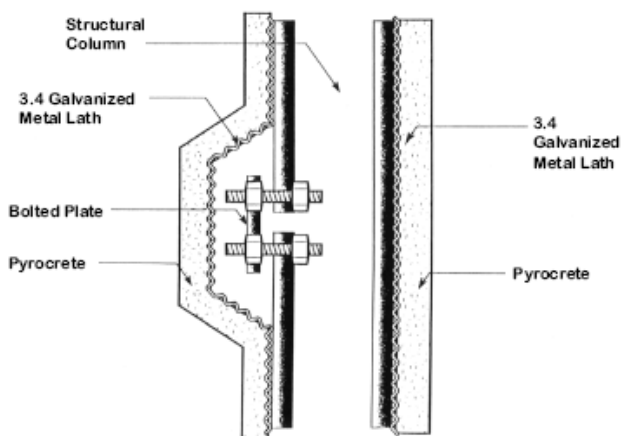

## TOWER SKIRT

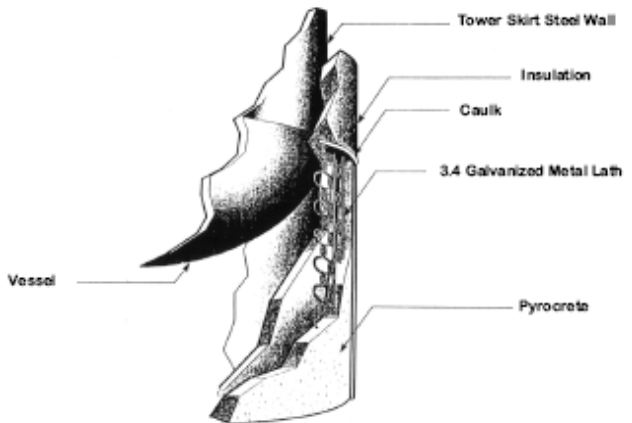

## TOWER SKIRT (2'- 4' DIAMETER)

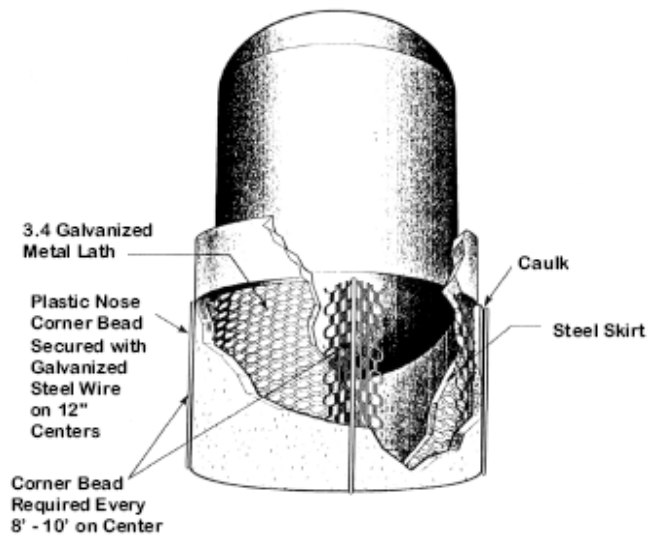

Manufactured / supplied by:-  
Altex Coatings Ltd, 91-111 Oropi Road,  
Tauranga 3112  
New Zealand  
Phone: +64 7 5411221  
Resene Paints Australia Ltd.  
T/A Altex Coatings  
7 Production Avenue  
Queensland 4214  
Australia  
Phone: +61 7 55949522



350 Hanley Industrial Court, St. Louis, MO 63144-1599  
314/644-1000 314/644-4617 (fax) www.carboline.com

An **RPM** Company